

11 POORVOTTAR NATYA SAMAROH

Set up 10th January 2019

Performance date – 11 – 19 January 2019

REQUIREMENT FOR DIMAPUR:

LIGHTS:

1. PC = 25 pcs
2. Par = 20 pcs
3. Profile = 5 pcs (50* , 36*)
4. LEDPAR (RGBW) = 10 pcs
5. Smoke = 2 pcs
6. Power pack (Dimmer) = 24 x 4 kw each
7. Console Board – Avolite or Any Programmable 48/60 channel Board.
8. T- Stand (14 foot high) – 2 pcs.
9. Stand Telescopic -- 6 pcs.
10. Colour Papers –All Colours
11. Cyc Flood – 8 Pcs.

Sound Requirement

Set up 10th January 2019

Performance date – 11 – 19 January 2019

1. Sound box – 4 pcs.
2. Monitor (on stage) – 2 pcs.
3. Mixer – 24 channel.
4. Mike(SM 57/58)(for vocal/instrument) – 6 pcs.
5. Floor mike – 4 pcs.
6. Amplifier – As required.
7. CD player – 1 pcs.
8. Tini to phono Jack – 2 pcs.
9. Condenser mike – 4 pcs.
10. Laptop – 1 pcs.

11TH POORVOTTAR NATYA SAMAOROH, DIMAPUR
FINAL SET UP 10TH JANUARY 2019
PERFORMANCE DATE – 11 – 19 JANUARY 2019

General Requirement:

1. Cyclorama (Black) – size – 32' x 16' -- 1 pcs.
2. Cyclorama (White) – size – 32' x 16' – 1 pcs.
3. Wings (Black) – 12' x 4' – 8 pcs.
4. Border/Frill (Black) – 30' x 4' – 6 pcs.
5. Welcome Gate – 1.
6. Stage for Platform Performance –Platform – 18'x12'x1'.
7. Ambience Decoration.

SET REQUIREMENTS FOR PLAYS

PLAY – AUTHO SANBAD BRITTA CHUNSILOK (11.01.19)

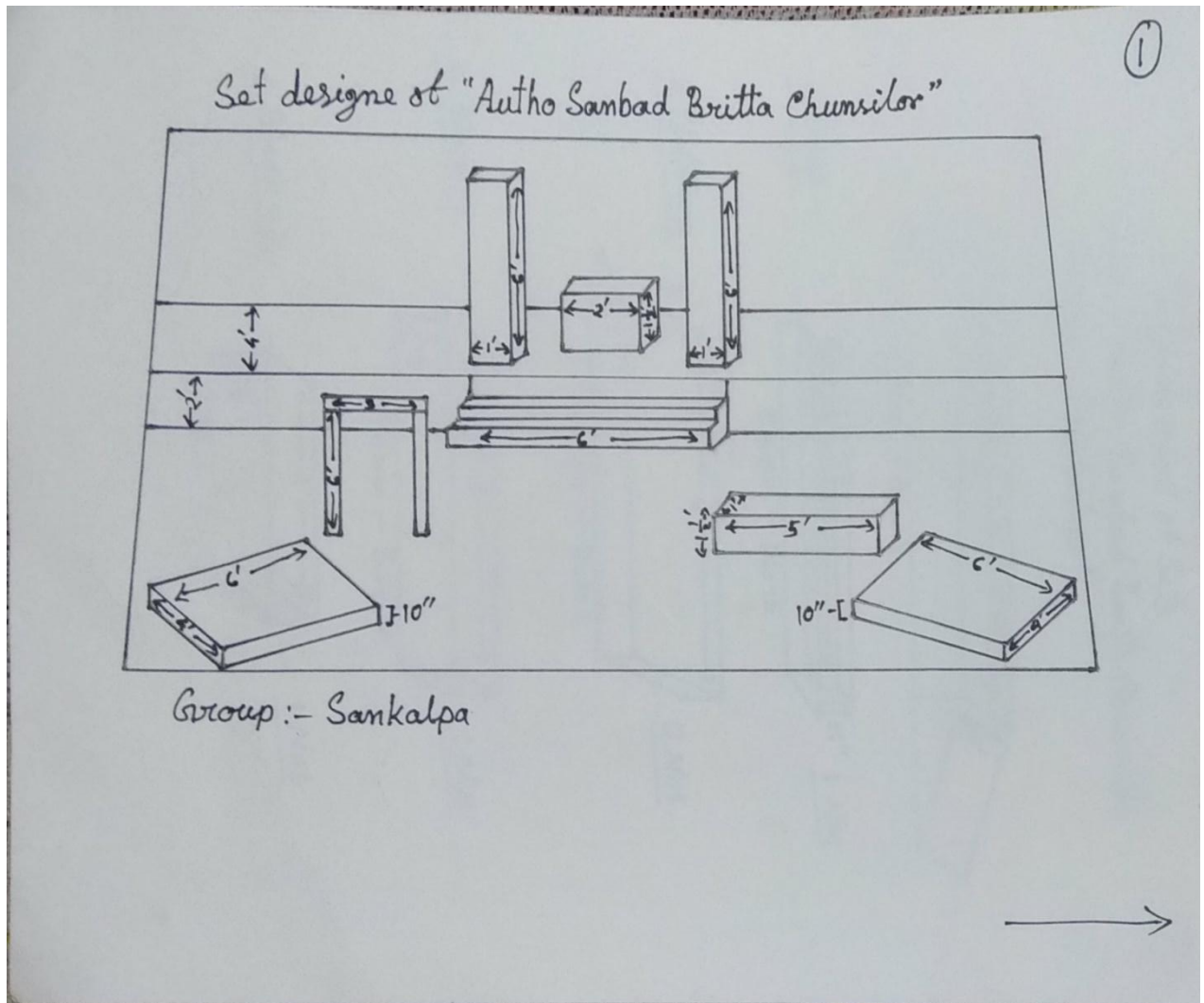

Requirement of Sets
Play:- "Aatho Sambad Britta Chunsilor"
Group:- Sankalpa

(2)

1. Ramp -

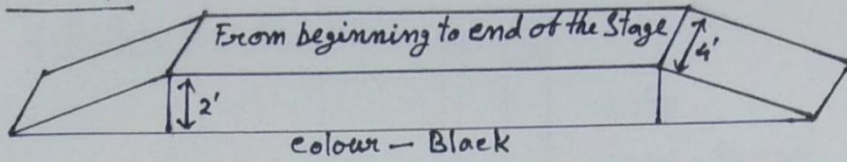

2. Step -

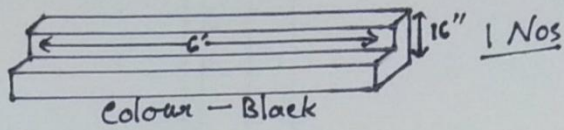

3. Platform -

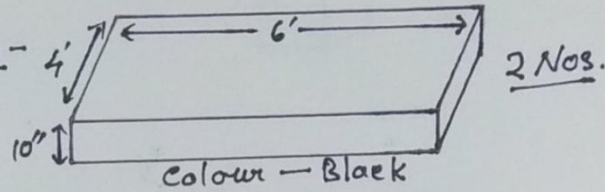

4. Block-1

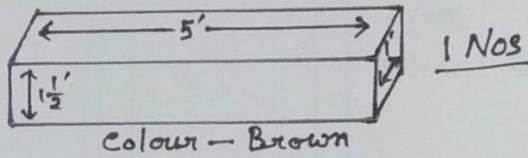

5. Block-2

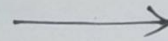
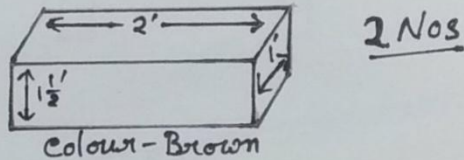

6. Pillar -

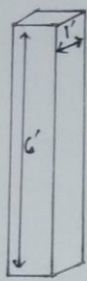

2 Nos
colour - Brown

7. Door Frame -

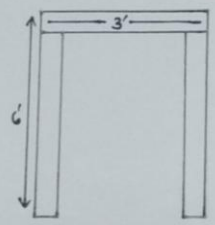

1 Nos
colour - Brown

8. Bamboo -

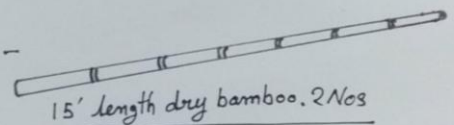

15' length dry bamboo. 2 Nos

PLAY - THENG FAKRI (12.01.19)

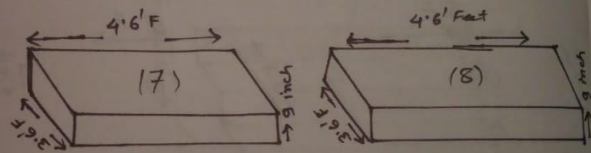

* Ramp - 9 inch height 4'6" x 3'6" Foot 2 Ramp

STEP

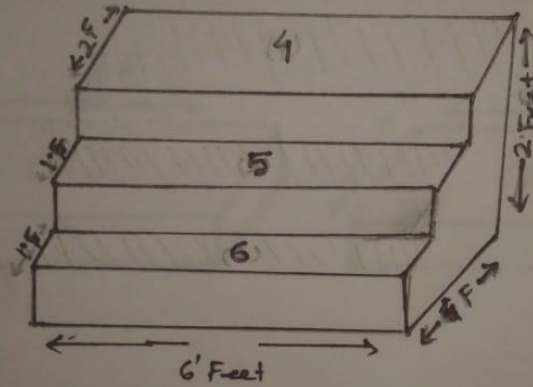

- (1) NO-1 Step - 6' x 1' x 9" height
- (2) NO-2 Step - 6' x 1' x 18" height
- (3) NO-3 Step - 6' x 2' x 2' height

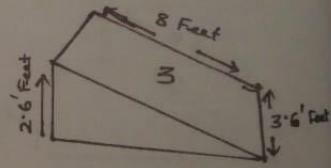
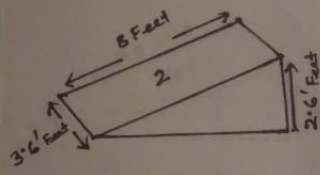
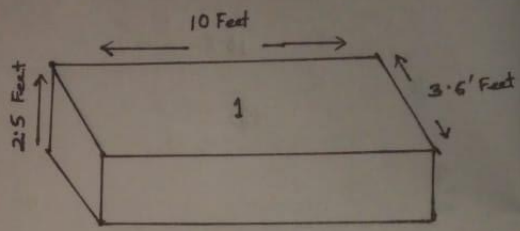

BAMBO WALL WITH STAND

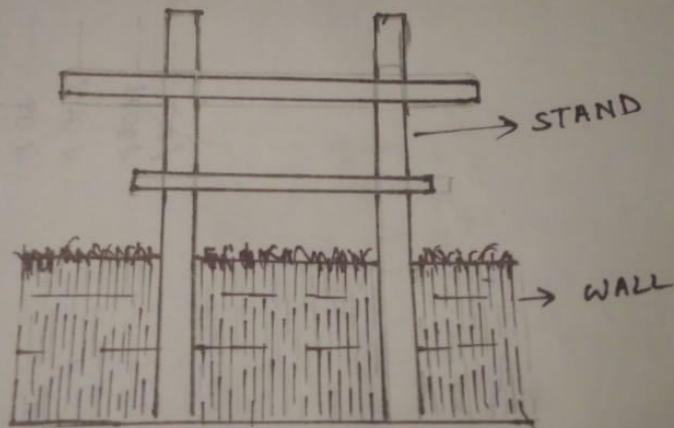

WALL → 4.5' x 2.5' (4.6 Long x 2.5 Height)
STAND → 5 Feet height x 3 Feet wide

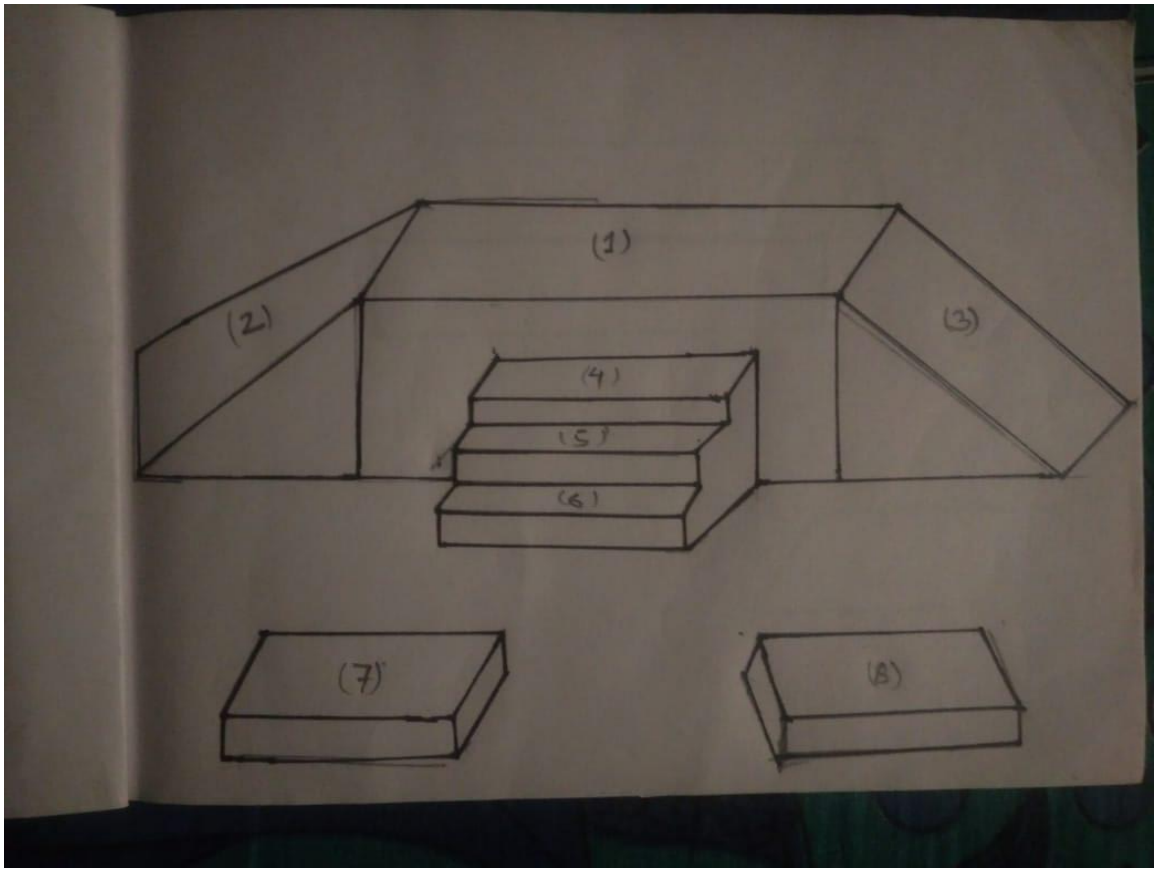

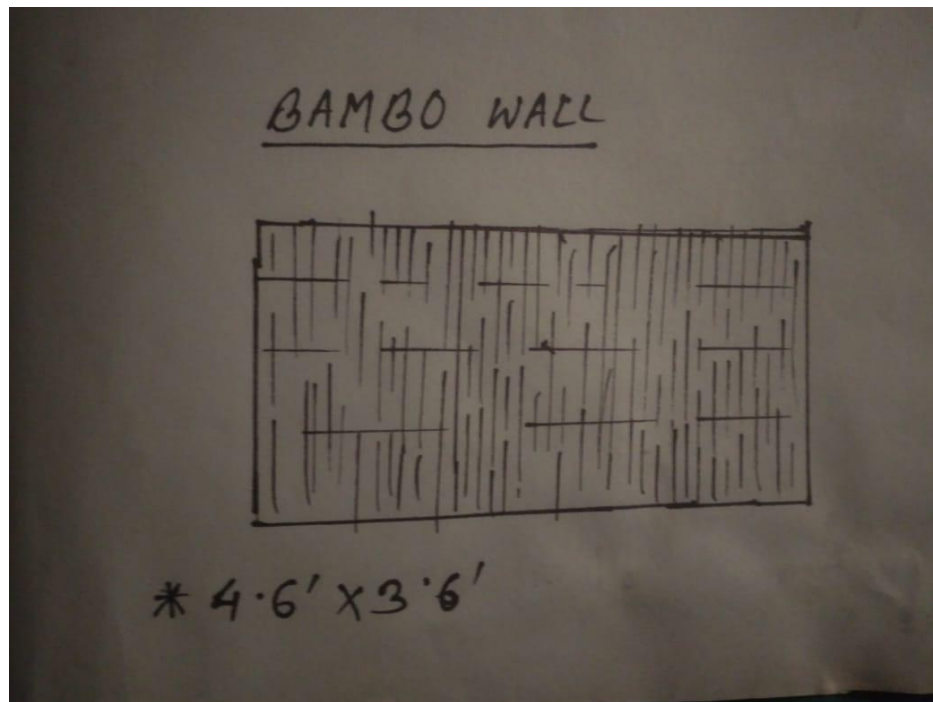

*On stage for settings:-

1. Jute ropes - 1 Kg
2. Large 20 bundles of straw or Haystack
3. Long bamboo slits - 6
4. Wooden beats- 5
5. Upright wall of bamboo of 3ft heightx 5 ft breadth

PLAY – ANUPOMA (14.01.19)

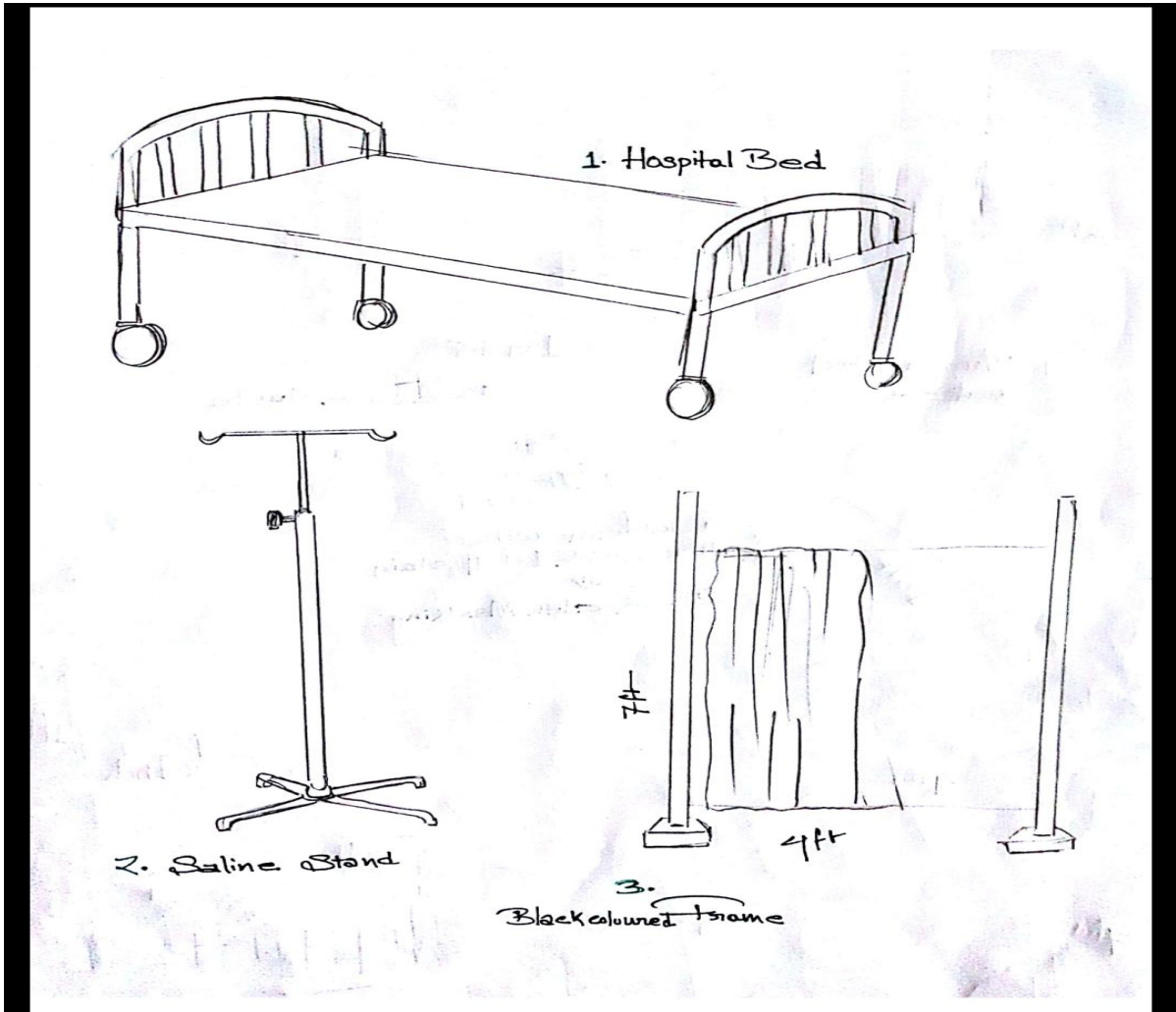

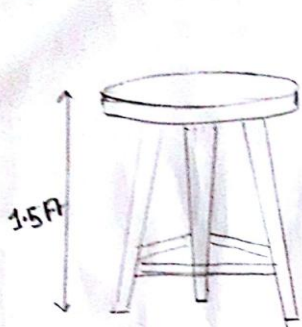

4. Wooden stool

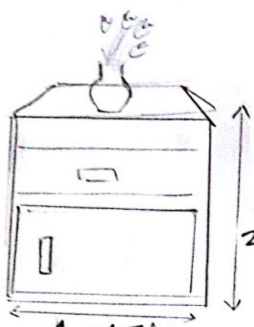

5. Bedside table

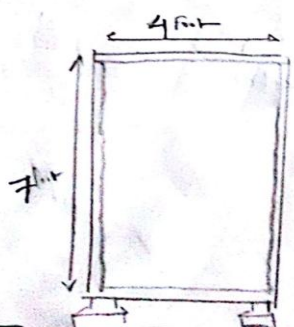
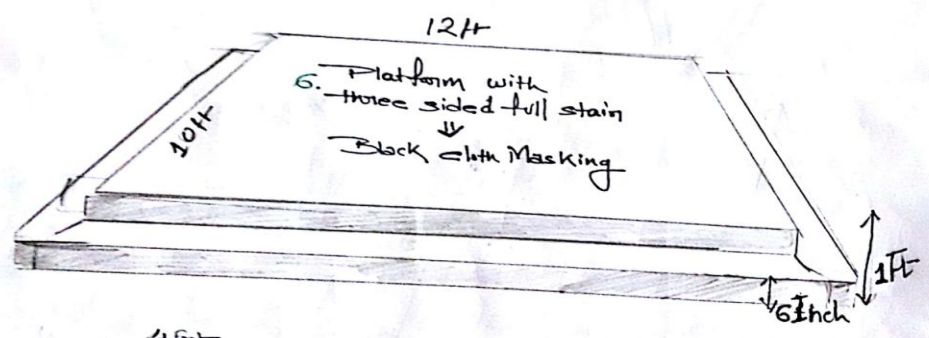

7. Wooden frame

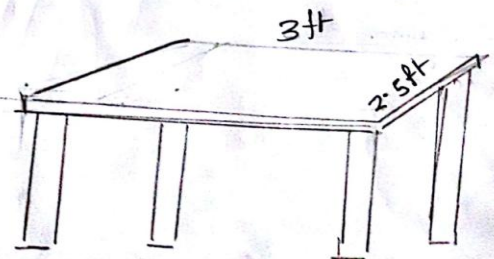

8. Normal wooden table

Scanned by CamScanner

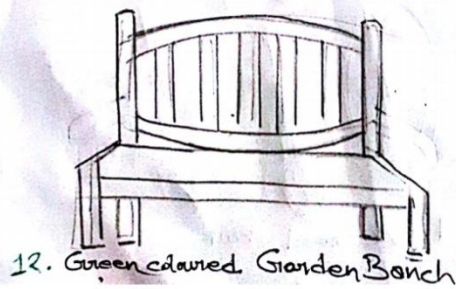
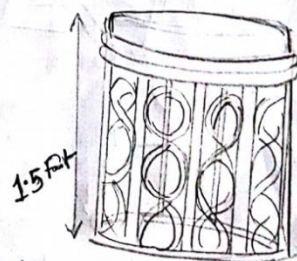
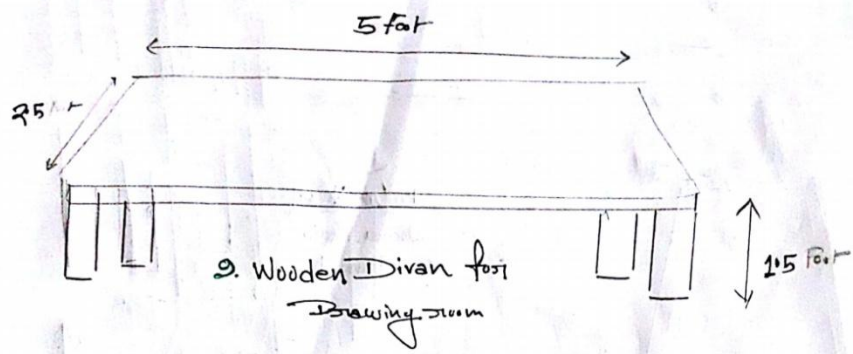

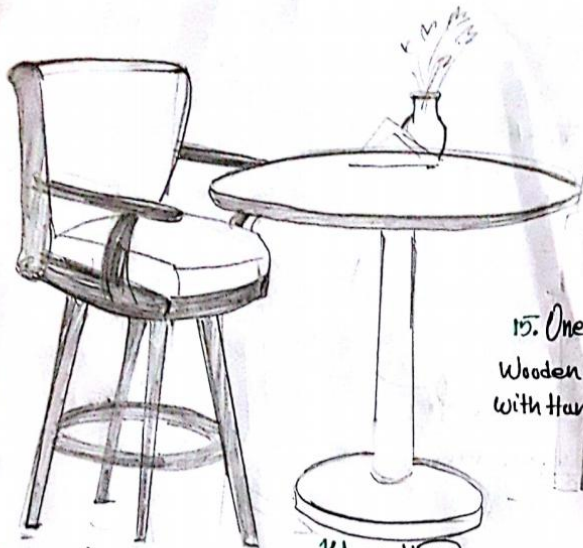

13. Sophisticated
Restaurant chair
Quant:- 2



14. Well furnished
Restaurant Round
Table

15. One Normal
Wooden chair
with handle

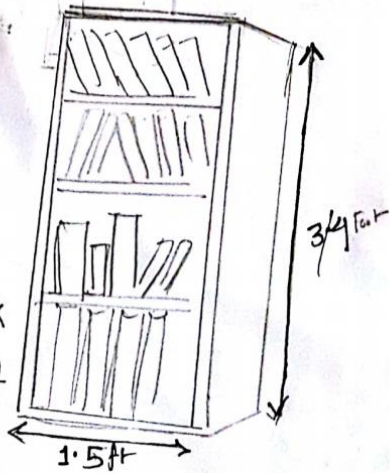

16. A thick
Wooden
Bookshelf

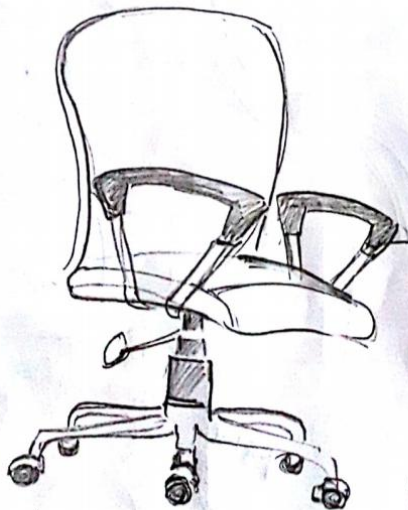

17. A Revolving chair



18. A wheel chair

PLAY – WAKCHINGEE NONGANLAMDAI (15.01.19)

Sheet 2 of 7

LAY OUT PLAN OF PLATFORM & AMBIENCE
FOR TRADITIONAL MANIPURI SHUMANG-LEELA OF SANGAI ARTISTES ASSN., IMPHAL
AT THE 18TH BHARAT RANG MAHOTSAV 2016, NEW-DELHI

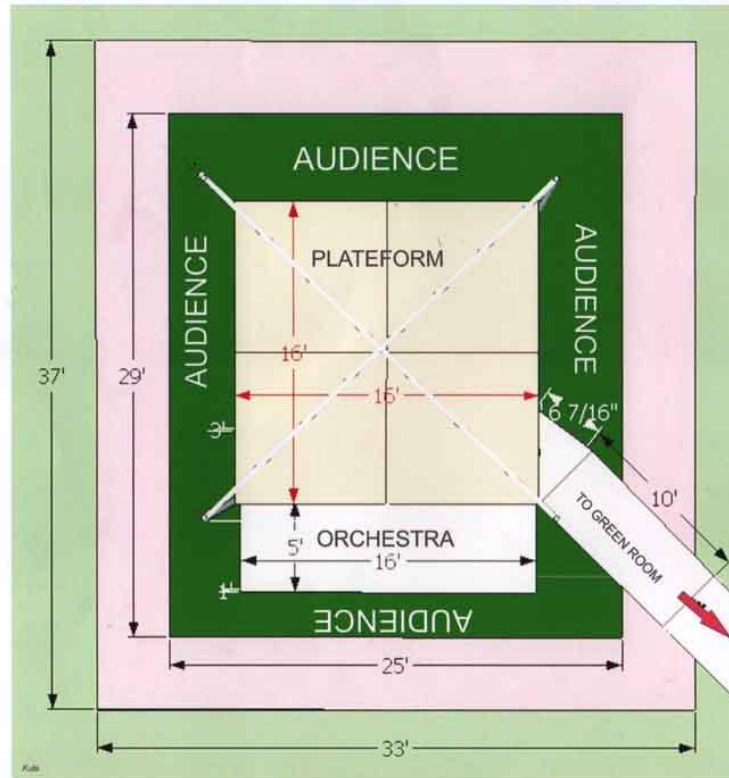

LAY OUT PLAN OF PLATFORM & AMBIENCE
FOR TRADITIONAL MANIPURI SHUMANG-LEELA OF SANGAI ARTISTES ASSN., IMPHAL
AT THE 18TH BHARAT RANG MAHOTSAV 2016, NEW-DELHI

Sheet 4 of 7

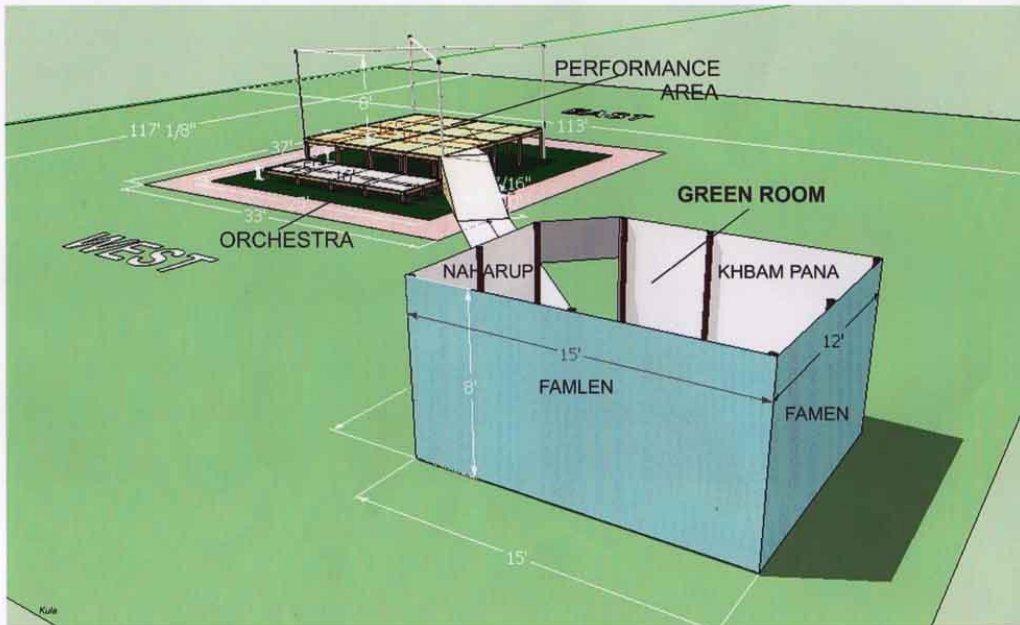

LAY OUT MODEL OF PLATFORM & AMBIENCE
FOR TRADITIONAL MANIPURI SHUMANG-LEELA OF SANGAI ARTISTES ASSN., IMPHAL
AT THE 18TH BHARAT RANG MAHOTSAV 2016, NEW-DELHI

Sheet 5 of 7

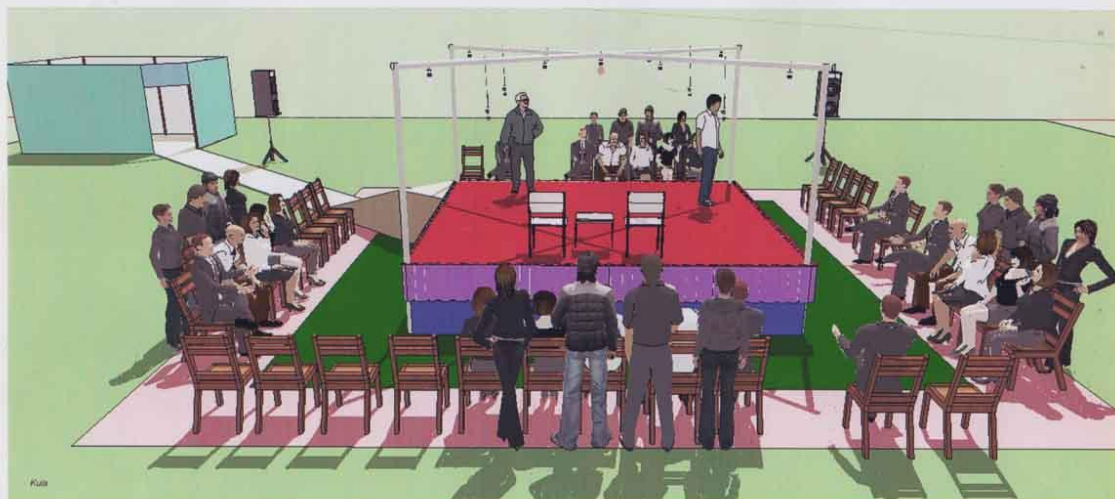

LAY OUT PLAN OF PLATFORM & AMBIENCE
FOR TRADITIONAL MANIPURI SHUMANG-LEELA OF SANGAI ARTISTES ASSN., IMPHAL
AT THE 18TH BHARAT RANG MAHOTSAV 2016, NEW-DELHI

Sheet 3 of 7

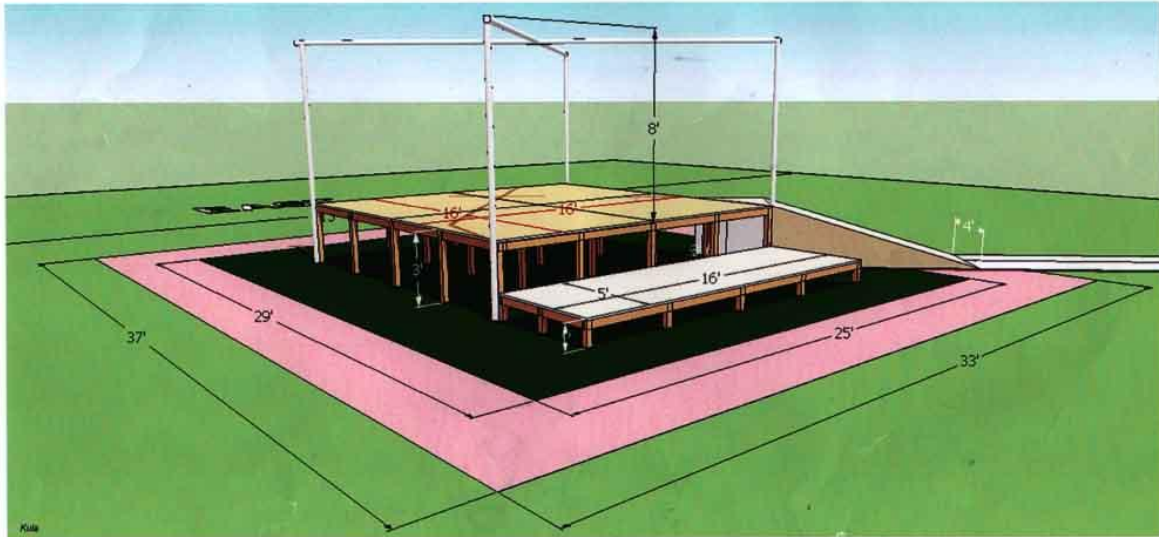

PLAY—RUKMINI HARAN (16.01.19)

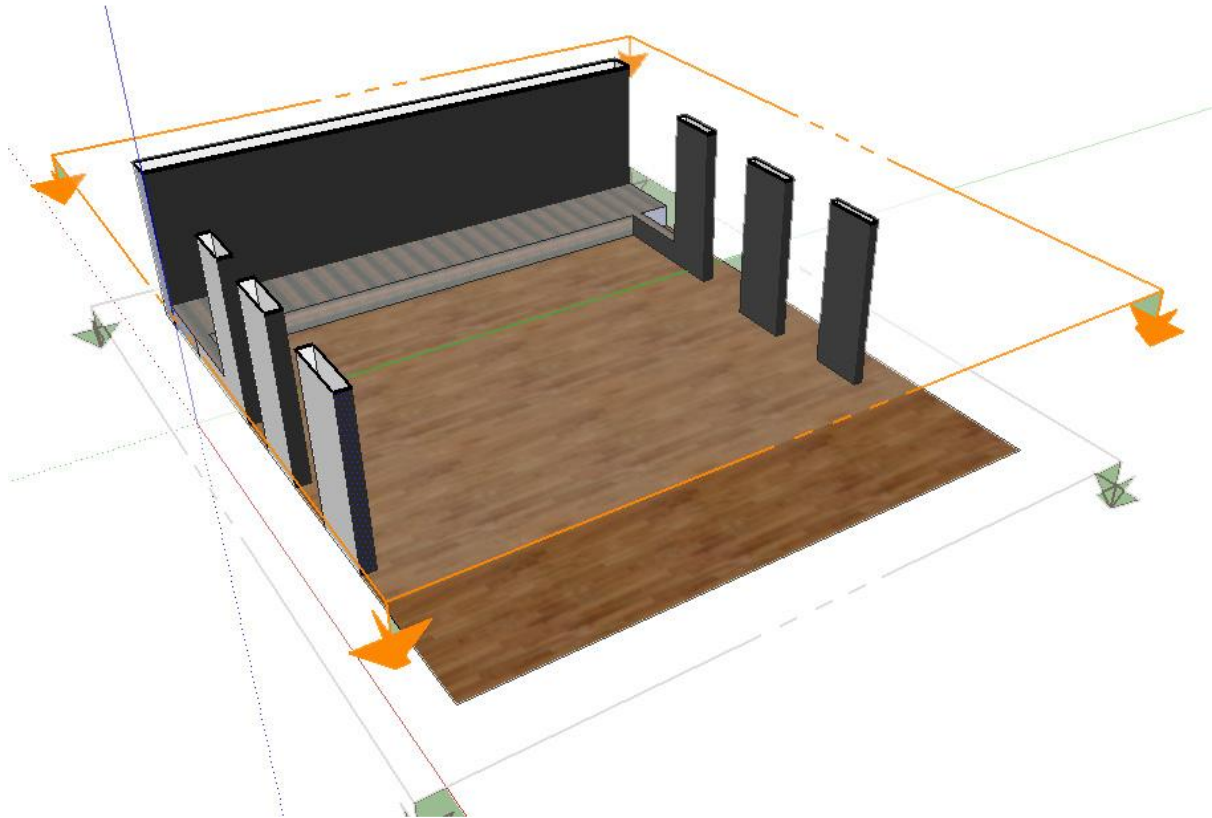

SET DETAILS REQUIRED FOR RUKMINI HARAN

1. Required 26 feet x 8 feet x 14 inch(Height) ramp on upstage.
2. 2 Nos post for Agnigarh, measuring 1½ inch (radius) x 7 feet(height), bamboo or Wooden.
3. Other Set and Properties will be carried by Abinaswar Gosthi, Nagaon.

PLAY – VIVAH: ETI BAHIR SUR (17.01.19)

Group will carry the set

PLAY – THE JOURNEY OF THE SORROW (18.01.19)

Platform – wing to wing -----

***Depth – 3 or 4 feet , Height – 9” or 1
feet.***

PLAY – SANSKAR (19.01.19)

"SANSKAR" SETTINGS

